

57.70 N 11.96 E

tripoint



# Tech & Soul

Scandi-design **eyewear**. Driven  
by environment & curiosity

tripoint

SS25



# GLASSES WITH A MISSION

We want to make accessible innovative sports glasses that respect the environment and protect your eyes throughout every moment of your life.



## **Design**

We love fashion, we love simple, we love innovative design.

We also love fair prices. So that cycling, skiing and traveling while being well protected remain moments that we can all enjoy.

## **Curiosity**

In 50 years, we want to be able to look back on the sports glasses industry and laugh. Knowing things have changed, and we have played a major role in the transformation.

## **Environment**

Whether it's about choosing our materials or selecting our partners, our glasses are manufactured according to a very strict set of specifications to ensure our products are safe and long-lasting.

Ever since we were kids, we have taken the environment for granted. But then we grew up and realized that nothing will last forever. That is why we have a sustainability mindset in everything we do.



# THE BEGINNING

Embark on a journey with Tripoint, where passion for design and an unwavering commitment to empowering athletes converge.



Our journey began with a shared passion for design and an unwavering commitment to empower athletes in reaching their pinnacle of success. As a group of visionaries, we set out to merge style with substance, creating sports glasses that not only elevate your performance but also embody the essence of cutting-edge design.

Driven by the belief that athletes deserve more than just gear – they deserve an experience – we embarked on a mission to craft products that seamlessly blend functionality with flair. Our love for sports and the athletes who fuel our inspiration motivates us to push the boundaries of innovation, ensuring every pair of Tripoint sports glasses is a testament to our dedication.

But it's not just about the glasses; it's about the athletes who wear them. We're here to be more than just a brand; we're their dedicated partners in the pursuit of greatness. Our commitment extends beyond delivering top-notch products to providing an unparalleled level of service. Your goals are our goals, and together, we strive to conquer new heights.



tripoint.com

# WHAT DOES TRIPOINT STAND FOR?



The name Tripoint is a geographical point at which the boundaries of three countries or subnational entities meet. This creates a unique place and binds countries together.

Tripoints can be found all over the world. There are approximately 176 international tripoints. We are humble and respectful to these surroundings. Knowing they can hit us with full force. That is why we adapt, that is why we prepare, that is why Tripoint exists. Made to withstand the harsh and variable climate and ready to take on every challenge.

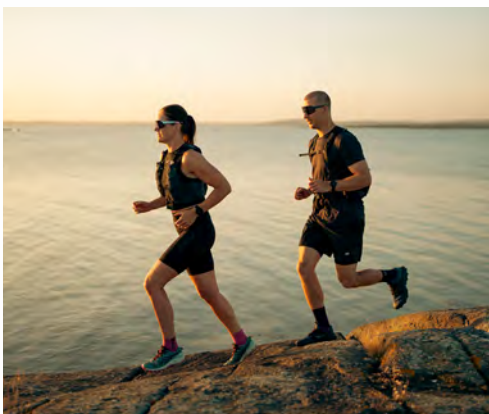



tripoint

---

**TRI-X VISION**  
Lens boost technology

When the surroundings and the weather conditions are harsh and unpredictable. Or you want a lens that is perfectly adapted to your purpose. The Tri-X Vision lens technologies are here to help.



## TRI-X | Polarized

The Tri-x polarized lens cuts out all reflecting light rays. No more glare from water, snow, wet roads or other reflecting materials.

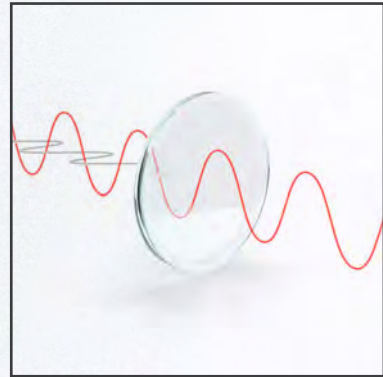

## TRI-X | UltraVue

The Tri-x contrast lens are made to boost colors and contrast in low light conditions. The lens blocks all the fuzzy colors in the color spectra. This results in a sharp, clear vision even in low light.

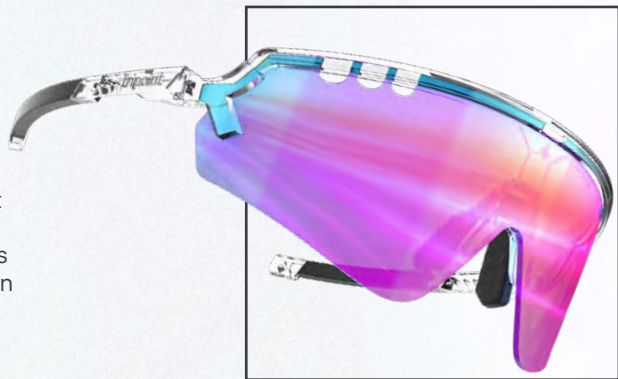

## TRI-X | Chromic

The Tri-x chromic lens are made to suit every weather condition. The lens changes its shading automatically and instantly from light to dark and back again based on the weather condition.

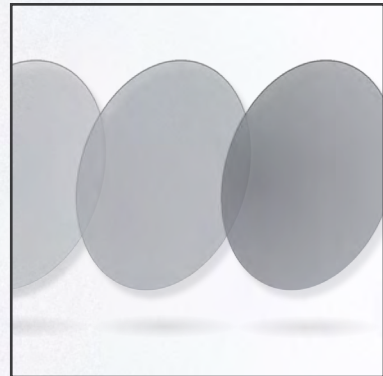

## BI<sup>o</sup>-BASED | Nylon lens

The Tri-x nylon lens offer the pleasure of a crisp clear vision. The comfort of ultralight weight. Safety in form of durability and shatter resistance.

Nylon as material are Bio-based and free from harmful BPA chemicals.



# TRI-X | Polarized

At sea	● ● ● ● ●	5
On the road	● ● ● ● ●	5
Fishing	● ● ● ● ●	5
Glacier	● ● ● ● ●	5

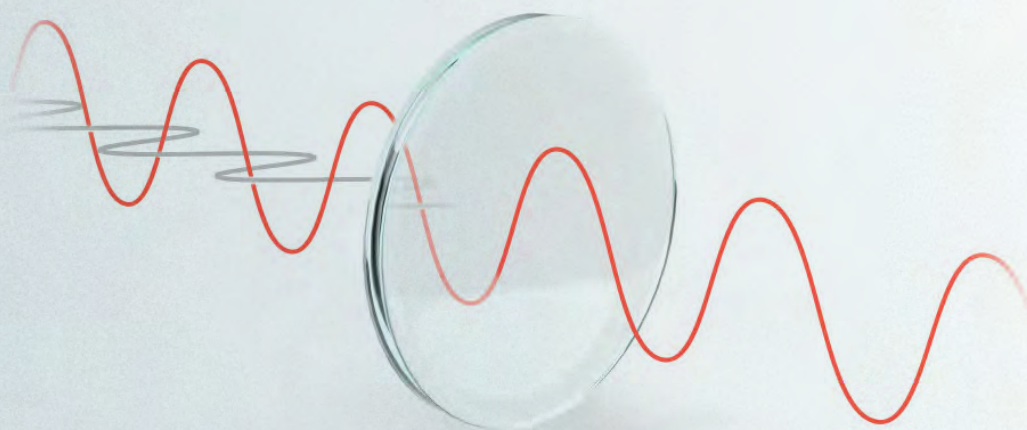

## | Polarized

Tired of being blinded by harsh glare when you're out and about? It's time to see the world in all its glory without the annoying distractions. Say hello to the Tri-x Polarized Lens – the ultimate solution to eliminate reflections and enhance your visual experience!

### **Glare-Free Clarity:**

Tri-x Polarized lenses are meticulously crafted to cut out all those pesky reflecting light rays. Whether it's blinding sunbeams on water, glistening snow, or slick, wet roads, our lenses ensure you see clearly without any distracting glare.

### **Uninterrupted Water Adventures:**

Love spending time by the water but hate the glare bouncing off the surface? Tri-x Polarized is your perfect companion for fishing, boating, or simply soaking up the sun by the beach. Dive into crystal-clear vision, and don't let glare spoil your aquatic fun!

### **Safely Navigate Snowy Slopes:**

Skiing or snowboarding on bright, sunny days?

Tri-x Polarized keeps your vision sharp without those blinding reflections on the slopes. Enjoy your winter adventures without squinting in the snow.

### **Safer Road Trips:**

Road trips are a breeze with Tri-x Polarized. Say goodbye to the blinding headlights of oncoming cars and the shimmering glare on wet roads. Drive safely and comfortably, day or night.

### **True Colors Shine Through:**

Our lenses not only eliminate glare but also reveal the true beauty of your surroundings. Experience vibrant colors, enhanced contrast, and a world filled with stunning detail.

Rediscover the world in all its glory with Tri-x Polarized. Don't let annoying reflections hinder your experiences – choose the lens that lets you see the world on your terms. Tri-x Polarized – where clarity meets style, and glare becomes a thing of the past!

## 001 Treriksroset Tri-x Polarized



**TRIS001-009**  
Frame: Shiny transparent black  
Lens: Polarized brown/silver mirror. Cat 3



**TRIS001-010**  
Frame: Shiny crystal  
Lens: Polarized brown/silver mirror. Cat 3

---

## 003 Reschen Tri-x Polarized



**TRIS003-110**  
Frame: Shiny transparent black  
Lens: Polarized brown/silver mirror. Cat 3



**TRIS003-111**  
Frame: Shiny crystal  
Lens: Polarized brown/silver mirror. Cat 3

---

## 007 Chobe Tri-x Polarized



**TS0007S001**  
Frame: Shiny transparent black  
Lens: Polarized brown/silver mirror. Cat 3



**TS0007S002**  
Frame: Shiny crystal  
Lens: Polarized brown/silver mirror. Cat 3

# TRI-X | Chromic

Indoor & night	● ● ● ● ●	5
Cloudy days	● ● ● ● ●	5
Bright & sunny days	● ● ● ● ●	5

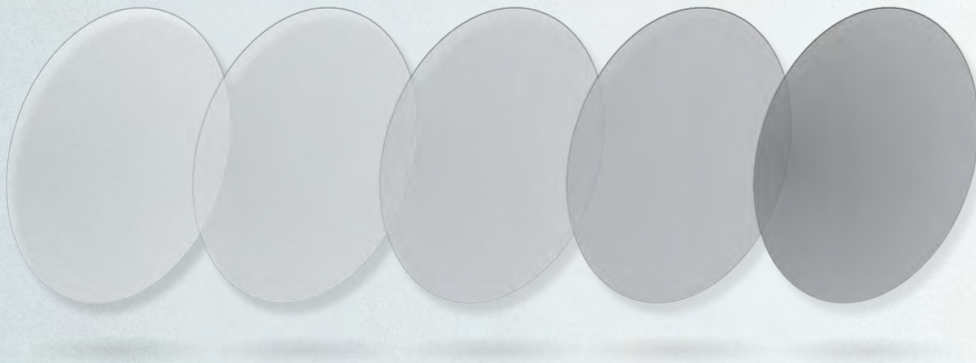

## | Chromic

Are you tired of constantly switching between different lenses to match ever-changing weather conditions? Say hello to the future of eyewear with Tri-x Chromic – the lens that adapts instantly to your surroundings!

### **Seamless Adaptation:**

Tri-x Chromic lenses are the perfect solution for unpredictable weather. They effortlessly transition from light to dark and back again, ensuring optimal visibility in any condition. No more squinting in bright sunlight or straining your eyes on cloudy days.

### **All-Weather Performance:**

Whether you're hitting the slopes on a sunny day or braving a sudden rainstorm, Tri-x Chromic has you covered. Say goodbye to the hassle of swapping lenses – enjoy your outdoor activities without interruption.

### **Uncompromised Clarity:**

Our advanced technology doesn't just adapt to changing light; it enhances your vision. With

Tri-x Chromic, you'll experience vivid colors and sharp details, no matter what Mother Nature throws your way.

### **Stylish and Functional:**

Tri-x Chromic lenses aren't just about performance; they're a style statement too. These sleek, modern lenses complement any frame, allowing you to look great while seeing clearly.

### **Instant Transition:**

The magic of Tri-x Chromic happens in the blink of an eye. Experience a lens that responds instantly to light conditions, providing you with the perfect shade when you need it most.

Be prepared for every moment with Tri-x Chromic and enjoy a seamless, adaptable visual experience like never before. Don't let changing weather dampen your day – embrace the future of eyewear with Tri-x Chromic! Your vision, your style, your comfort – all in one remarkable lens.

## 001 Treriksröset Tri-x Chromic



**TRIS001-007**  
Frame: Shiny transparent black  
Lens: Photochromic smoke/blue multi. Cat 0-3

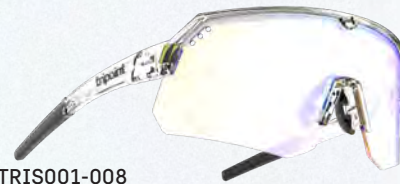

**TRIS001-008**  
Frame: Shiny crystal  
Lens: Photochromic smoke/blue multi. Cat 0-3

## 003 Reschen Tri-x Chromic



**TRIS003-108**  
Frame: Shiny transparent black  
Lens: Photochromic smoke/blue multi. Cat 0-3



**TRIS003-109**  
Frame: Shiny crystal  
Lens: Photochromic smoke/blue multi. Cat 0-3

## 007 Chobe Tri-x Chromic



**TS0007S003**  
Frame: Shiny transparent black  
Lens: Photochromic smoke/blue multi. Cat 0-3



**TS0007S004**  
Frame: Shiny crystal  
Lens: Photochromic smoke/blue multi. Cat 0-3

## 005 Lake Victoria Tri-x Chromic



**TRIS00515**  
Frame: Shiny transparent black  
Lens: Photochromic smoke/blue multi. Cat 0-3

## 005 Lake Victoria Small Tri-x Chromic



**TRIS00616**  
Frame: Shiny transparent black  
Lens: Photochromic smoke/blue multi. Cat 0-3



**TRI-X** | UltraVue

Contrast enhancer ● ● ● ● ● 5

Low light conditions ● ● ● ● ● 5

## | UltraVue

Are you tired of dull, fuzzy visuals in low-light conditions while enjoying your favorite activities? Say goodbye to those frustrating moments, because Tri-x UltraVue is here to revolutionize your experience!

### Enhanced Color and Contrast:

Tri-x UltraVue lenses are expertly designed to intensify colors and contrast in low-light settings. No more struggling to distinguish details or battling the blur of fuzzy colors – our lenses cut through the haze for a vibrant, crisp view!

### Optimal Clarity in Low Light:

Whether you're hitting the slopes at dusk, venturing out for an evening hike, or simply navigating dimly lit environments, Tri-x UltraVue ensures you see with precision. Our advanced technology lets you enjoy every moment with unparalleled clarity.

### Versatile Performance:

Tri-x UltraVue lenses aren't just for one activity; they're your all-in-one solution for any low-light situation. From skiing and snowboarding to nighttime strolls and indoor events, you can trust Tri-x to enhance your vision every time.

### See the World in True Colors:

Experience the world as it's meant to be seen – vibrant, sharp, and full of detail. Tri-x UltraVue lenses block out the noise of fuzzy colors, revealing the true beauty around you, even when the sun has set.

Become one with your vision and seize every moment, no matter the lighting conditions. Discover the Tri-x UltraVue difference today and elevate your visual experience to new heights! Don't settle for less when you can have the best.

## | 005 Lake Victoria Tri-x UltraVue



**TS0007S005**  
Frame: Shiny transparent black  
Lens: UltraVue Orange/blue multi. Cat 1

## | 006 Lake Victoria Small Tri-x UltraVue



**TS0007S005**  
Frame: Shiny transparent black  
Lens: UltraVue Orange/blue multi. Cat 1



**TS0007S007**  
Frame: Shiny transparent black  
Lens: UltraVue violet/blue multi. Cat 2



**TS0007S007**  
Frame: Shiny transparent black  
Lens: UltraVue violet/blue multi. Cat 2

## 001 Treriksroset

Tri-x UltraVue



**TRIS001-001**  
Frame: Shiny transparent black  
Lens: UltraVue Orange/blue multi. Cat 1



**TRIS001-003**  
Frame: Shiny transparent black  
Lens: UltraVue violet/blue multi. Cat 2



**TRIS001-002**  
Frame: Shiny crystal  
Lens: UltraVue Orange/blue multi. Cat 1



**TRIS001-004**  
Frame: Shiny crystal  
Lens: UltraVue violet/blue multi. Cat 2

---

## 003 Reschen

Tri-x UltraVue



**TRIS003-101**  
Frame: Shiny transparent black  
Lens: UltraVue Orange/blue multi. Cat 1



**TRIS003-103**  
Frame: Shiny transparent black  
Lens: UltraVue violet/blue multi. Cat 2



**TRIS003-102**  
Frame: Shiny crystal  
Lens: UltraVue Orange/blue multi. Cat 1



**TRIS003-104**  
Frame: Shiny crystal  
Lens: UltraVue violet/blue multi. Cat 2

---

## 007 Chobe

Tri-x UltraVue



**TS0007S005**  
Frame: Shiny transparent black  
Lens: UltraVue Orange/blue multi. Cat 1



**TS0007S007**  
Frame: Shiny transparent black  
Lens: UltraVue violet/blue multi. Cat 2



**TS0007S006**  
Frame: Shiny crystal  
Lens: UltraVue Orange/blue multi. Cat 1



**TS0007S008**  
Frame: Shiny crystal  
Lens: UltraVue violet/blue multi. Cat 2

## BIO-BASED | Nylon lens

Extreme clarity	● ● ● ● ●	5
Sustainable	● ● ● ● ●	5
Ultralight	● ● ● ● ●	5
BPA-free	● ● ● ● ●	5



## | Nylon lens

### **Unobstructed vision with biobased nylon lenses**

For maximal safety and top performance it is important that your glasses do not obstruct your vision and only enhance it. Tripoint comes with a biobased Nylon lens with extremely high optical quality. The Nylon lens is both lighter and provides a clearer view than Polycarbonate, which is the most common material for lenses in sports glasses. The lens is also flexible, resistant and has a good "memory". If you bump or bend them, they will return to their original shape. Nylon as a material is also free from BPA, which is a chemically harmful substance for the body. Not only does the lens provide better performance, but it also has less impact on the environment in the manufacturing process.

Tripoint also offers an endless amount of interchangeable lenses to maximize vision in the widest variety of different weather conditions. Tripoint complies with standards EN ISO 12312-1, AS/NZS 1067 & ANSI Z80.3.

### **Light weight biobased nylon frame**

The biobased frame is made of a strong lightweight Nylon material and puts minimal strain on the nose, ears and environment thanks to the low weight and biobased material. To ensure maximum mobility for the head and minimum tension in the neck, Tripoint sports glasses are superlight, they often weight less than 40g.



| 001 Treriksröset  
Biobased Nylon lens

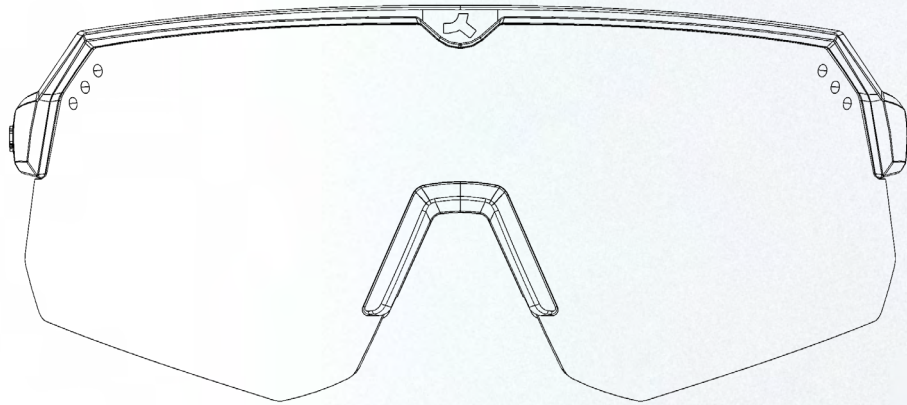

| 002 Jongsong Peak  
Biobased Nylon lens

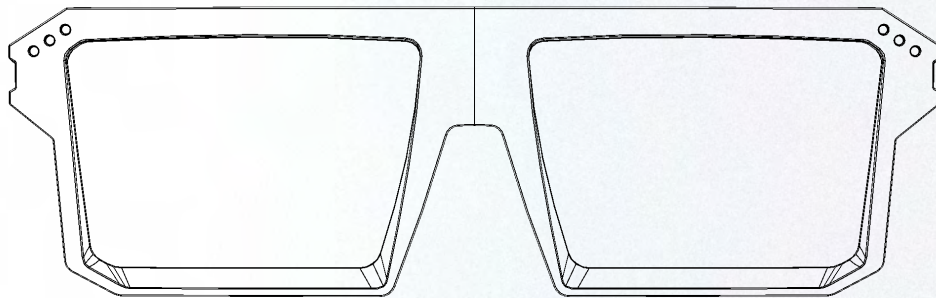

| 003 Reschen  
Biobased Nylon lens

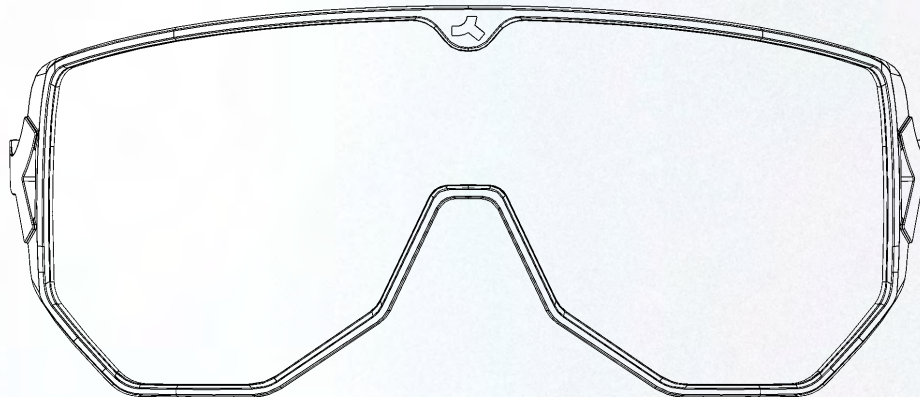

# WHY TRIPOINT SPORTS GLASSES?



**Biobased nylon frame:** Tripoint Sports Glasses are meticulously engineered and crafted using top-tier bio-based materials, ensuring durability in the face of challenging conditions, lasting for seasons of intense sports activities.

**Optimal Visibility:** These sports glasses deliver unparalleled visibility, thanks to cutting-edge lens technology that enhances clarity and minimizes glare with 100% UV-protection. Whether you're cycling, skiing, or participating in outdoor adventures, Tripoint Sports Glasses offer crystal-clear vision.

**Customized Comfort:** Tailored for comfort, Tripoint Sports Glasses are often adjustable in both nose (Tri-click nose system™) and temples (Tri-bend temple tips™) to securely fit any face shape. Their ergonomic design minimizes pressure points, allowing you to concentrate on your athletic pursuits without distraction.

**Lightweight Design:** Recognizing the need for agility in sports, Tripoint Sports Glasses boast a lightweight design. Say goodbye to the burden of heavy eyewear, empowering you to navigate challenging terrain effortlessly and focus on your athletic pursuits with unmatched ease.

**Trusted by world-class athletes:** Join the ranks of elite competitors who choose Tripoint for precision, durability, and unrivaled performance. When the best athletes in the world trust Tripoint, you know you're in good company.



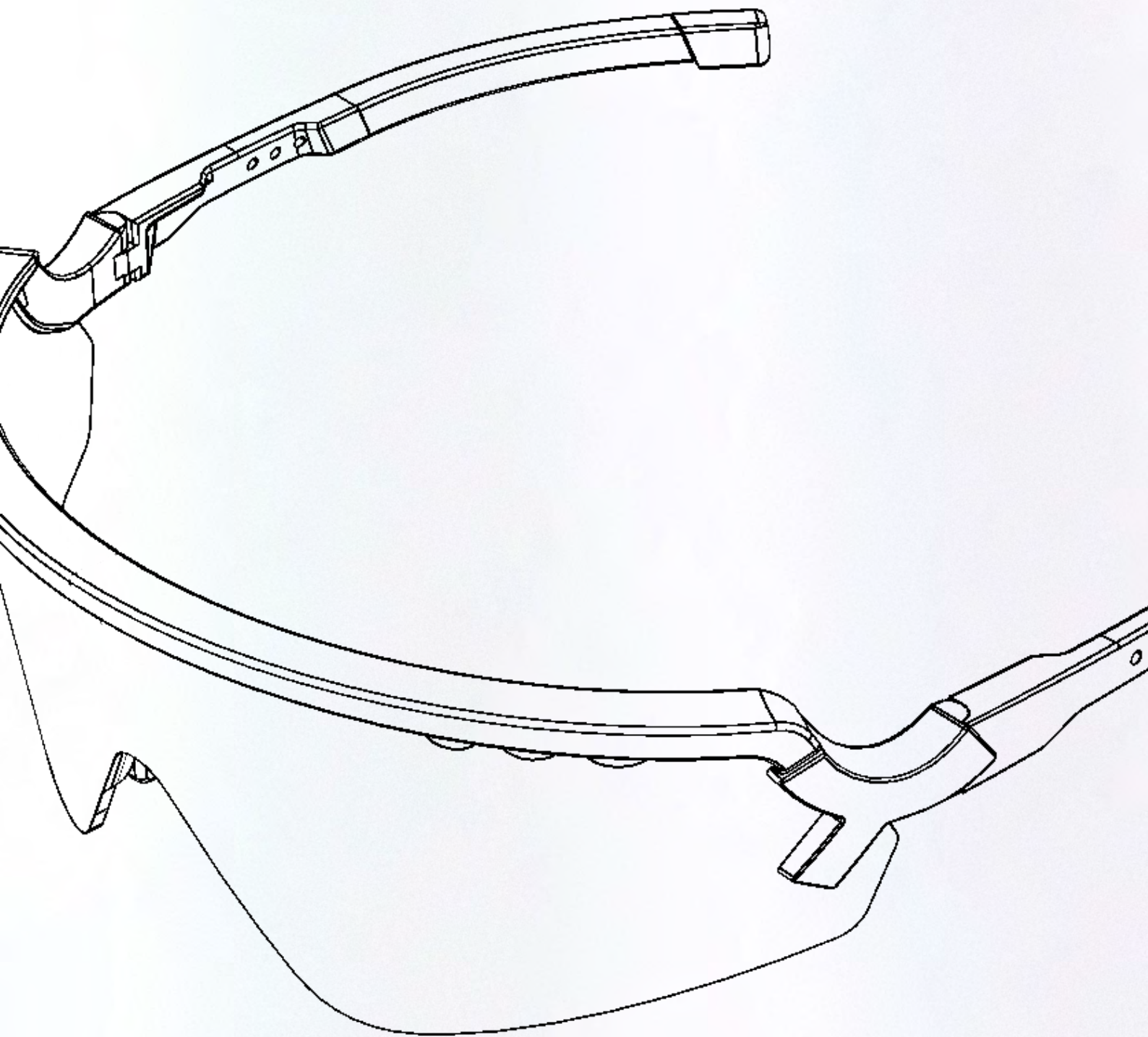

69°03'35"N 20°32'49"E

# 001 Treriksörset

Tech & Soul

BIO-  
BASED

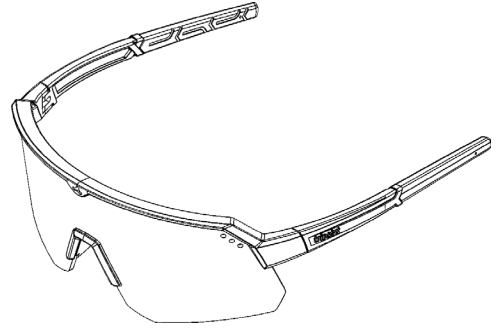

## Description

30 years of experience in the sport and fashion eyewear industry has led us to this style - 001 Treriksörset. Treriksörset is the ideal model for speed sports such as mountain biking, road biking or skiing. But still just as stylish to be able to fit on a catwalk. A sober and pure design, combining style and technicality: Its wrap-around lens offers optimal protection against the wind generated by speed, but also against branches that you may encounter on your way.

Enjoy increased peripheral vision and clarity with the biobased Nylon lens, an essential factor in improving your visual accuracy and therefore, your sporting performance! Its 100% UV protective lens will counteract tired eyes for many years to come.

A durable model designed to last: 001 Treriksörset is made of 45% organic polyamide sourced from castor oil, carefully selected for its lightness, flexibility and resistance to shocks.

Keep your 001 Treriksörset in top condition: the storage pouch is specially designed to keep your shades safe. And the cleaning wipe keeps the dirt away, for permanent visual comfort.

### Standards

This model meets the standards EN ISO 12312-1, AS/NZS 1067 & ANSI Z80.3 for sunglasses.

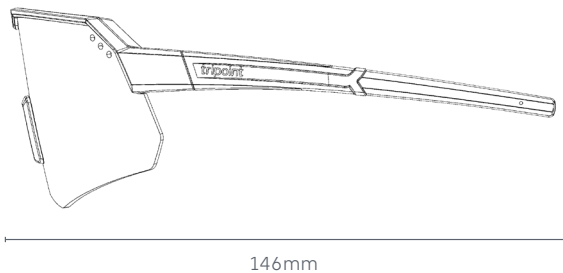

146mm

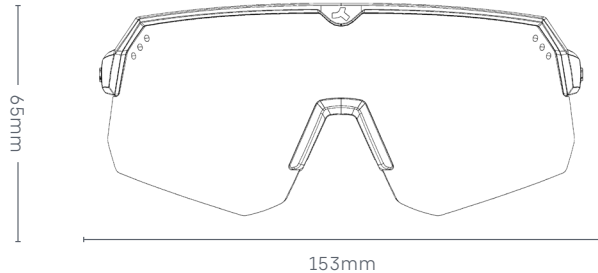

65mm

153mm

## Technical Features

### Tri-click nose System

The unique system makes the nose part easy to adjust and maintains the shape that the user himself specified. The nose part is rubber-coated and provides the user with comfort during longer and tougher forms of activity.

### Tri-bend temple tips

The rubberized temple tips are adaptable and easy to adjust to your head for a stable and comfortable use for extended periods.

### Tri-field wrap-around

The wrap-around frame provides a wide field of vision and enhanced peripheral eyesight to ensure optimal visual accuracy and improve your sports performance.

### Biobased Nylon frame

The frame is made of 45% organic sourced polyamide with castor oil. The nylon material is both strong and light weighted. The Frame puts minimal strain on the nose, ears and environment at the same time.

### Biobased Nylon lens

The Biobased Nylon lens is both lighter and provides a clearer view than Polycarbonate, which is the most common material for lenses in sports glasses. The lens is flexible, resistant and has a good "memory". If you bump or bend them, they will return to their original shape. Nylon as a material is also free from BPA which is a chemically harmful substance for the body.

### Hydrophobic/Oleophobic

Our top of the line Hydrophobic + Oleophobic treatment ensures water, oil and dirt pearl off your lenses.

### Tri-dot ventilation

The right amount of air ventilation can be important to keep the fog away. Our tri-dots provide the user with enough air circulation for a fog-free experience.

### 100% UV400 Protection

Our lenses block all harmful UVA, UVB & UVC light rays with wavelengths up to 400 nanometers – regardless of sun or cloud conditions.

### Interchangeable lens

The weather conditions can suddenly change, then it might be handy to have a spare lens ready. On this frame, you can easily change from one lens to a lens that is best suited for the moment. Spare lenses are available for purchase.

### Optical insert (available as an accessory)

RX-able optical insert which can be taken to an optician and fitted with your own prescription lenses.

### Click hinge

High quality click hinge for a long-lasting temple. Free from squeaking sound, loose screws and unexpected folding.



**TRIS001-BL-063**  
 Frame: Matt black  
 Lens: Nylon smoke/blue multi. Cat 3



**TRIS001-BR-103G**  
 Frame: Transparent brown  
 Lens: Nylon gradient brown. Cat 2



**TRIS001-BL-003**  
 Frame: Matt black  
 Lens: Nylon smoke. Cat 3



**TRIS001-BE-073**  
 Frame: Matt turquoise  
 Lens: Nylon smoke/pink multi. Cat 3



**TRIS00116**  
 Frame: Matt white  
 Lens: Nylon brown/pink multi. Cat 3



**TRIS00115**  
 Frame: Matt pink  
 Lens: Nylon brown/pink multi. Cat 3



**TRIS001-009**  
 Frame: Shiny transparent black  
 Lens: Polarized brown/silver mirror. Cat 3



**TRIS001-010**  
 Frame: Shiny crystal  
 Lens: Polarized brown/silver mirror. Cat 3



**TRIS001-001**  
 Frame: Shiny transparent black  
 Lens: Nylon orange/blue multi. Cat 1



**TRIS001-002**  
 Frame: Shiny crystal  
 Lens: Nylon orange/blue multi. Cat 1



**TRIS001-003**  
 Frame: Shiny transparent black  
 Lens: Nylon violet/blue multi. Cat 2



**TRIS001-004**  
 Frame: Shiny crystal  
 Lens: Nylon violet/blue multi. Cat 2



**TRIS001-007**  
 Frame: Shiny transparent black  
 Lens: Photochromic smoke/blue multi.  
 Cat 0-3



**TRIS001-008**  
 Frame: Shiny crystal  
 Lens: Photochromic smoke/blue multi.  
 Cat 0-3

## Spare lenses



Art.No	Spare lens
TRISL001-8	Clear - CAT 0
TRISL001-7	Pink - CAT 1
TRISL001001	Polarized brown w silver mirror - CAT 3
TRISL001002	UltraVue orange with blue multi - CAT 1
TRISL001003	UltraVue violet with blue multi - CAT 2
TRISL001004	Smoke with blue multi - CAT 3
TRISL001005	Brown - CAT 4

## Optical adapter



Art.No	Color
TRIS001-OA-BL	Black
TRIS001-OA-WH	White
TRIS001-OA-BR	Transparent brown
TRIS001-OA-BE	Petrol
TRIS001-OA-PI	Powder pink
TRIS001-OA-RD	Burgundy
TRIS001-OA-YL	Transparent yellow
TRIS001-OA-BET	Transparent turquoise

27°53'N 88°8'E

# 002 Jongsong Peak

Free & Strong

BI<sup>o</sup>-  
BASED

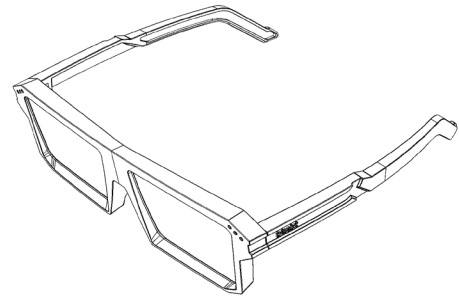

## Description

Innovative hybrid frame that flirts with the eyewear fashion industry. 002 Jongsong Peak is a versatile model that works best when your everyday life flows into one. You want to train, work, study, travel, have coffee and go to a party. But can't you have only one pair of glasses for all of that? Well... Jongsong Peak allows you to mix function, technology and fashion awareness. All at the same time.

Enjoy crisp and clear vision with the biobased Nylon lens, an essential factor in improving your visual accuracy and therefore, your sporting performance! Its 100% UV protective lens will counteract tired eyes for many years to come.

A durable model designed to last: 002 Jongsong Peak is made of 45% organic polyamide sourced from castor oil, carefully selected for its lightness, flexibility and resistance to shocks.

Keep your 002 Jongsong Peak in top condition: the storage pouch is specially designed to keep your shades safe. And the cleaning wipe keeps the dirt away, for permanent visual comfort.

### Standards

This model meets the standards EN ISO 12312-1, AS/NZS 1067 & ANSI Z80.3 for sunglasses.

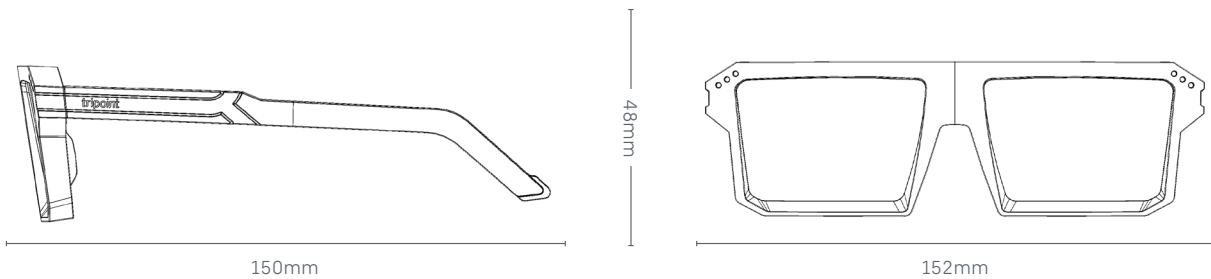

## Technical Features

### Comfy rubber temple tips

The rubberized temple tips are adaptable and easy to adjust to your head for a stable and comfortable use for extended periods.

### Biobased Nylon frame

The frame is made of 45% organic sourced polyamide with castor oil. The nylon material is both strong and light weighted. The Frame puts minimal strain on the nose, ears and environment at the same time.

### Biobased Nylon lens

The Biobased Nylon lens is both lighter and provides a clearer view than Polycarbonate, which is the most common material for lenses in sports glasses. The lens is flexible, resistant and has a good "memory". If you bump or bend them, they will return to their original shape. Nylon as a material is also free from BPA which is a chemically harmful substance for the body.

### Hydrophobic/Oleophobic

Our top of the line Hydrophobic + Oleophobic treatment ensures water, oil and dirt pearl off your lenses.

### 100% UV400 Protection

Our lenses block all harmful UVA, UVB & UVC light rays with wavelengths up to 400 nanometers – regardless of sun or cloud conditions.

### Click hinge

High quality click hinge for a long-lasting temple. Free from squeaking sound, loose screws and unexpected folding.

Overview

# 002 Jongsong Peak

---



TRIS002-BL-003  
Frame: Matt black  
Lens: Nylon smoke. Cat 3

46°50'53"N 10°30'18"E

# 003 Reschen

Life & Globe

BIO-  
BASED

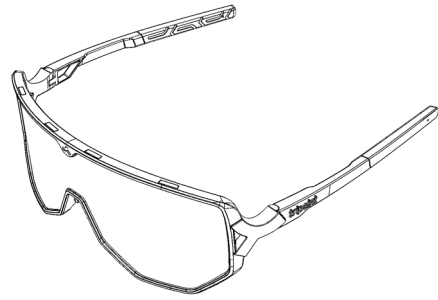

## Description

003 Reschen is the perfect companion for a life in motion. The world has so much to offer, people, nature, activities, culture. You want to absorb everything, you are curious. Around the next bend, new adventures, new surprises await. Unpredictability is what makes you feel good, unpredictability is what these glasses are made for.

Enjoy increased peripheral vision and clarity with the biobased Nylon lens, an essential factor in improving your visual accuracy and therefore, your sporting performance! Its 100% UV protective lens will counteract tired eyes for many years to come.

A durable model designed to last: 003 Reschen is made of 45% organic polyamide sourced from castor oil, carefully selected for its lightness, flexibility and resistance to shocks.

Keep your 003 Reschen in top condition: the storage pouch is specially designed to keep your shades safe. And the cleaning wipe keeps the dirt away, for permanent visual comfort.

### Standards

This model meets the standards EN ISO 12312-1, AS/NZS 1067 & ANSI Z80.3 for sunglasses.

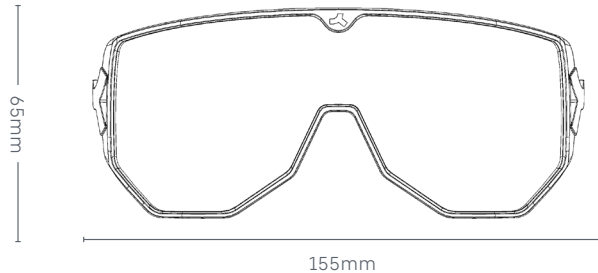
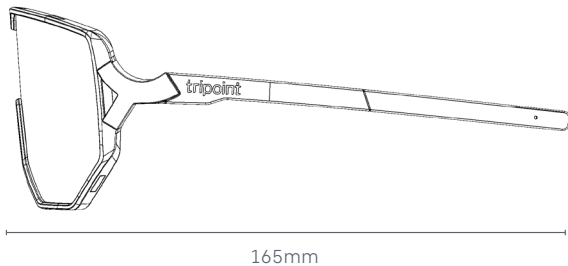

## Technical Features

### Tri-click nose system

The unique system makes the nose part easy to adjust and maintains the shape that the user himself specified. The nose part is rubber-coated and provides the user with comfort during longer and tougher forms of activity.

### Tri-bend temple tips

The rubberized temple tips are adaptable and easy to adjust to your head for a stable and comfortable use for extended periods.

### Tri-field full frame

The full-frame provides a wide field of vision and enhanced peripheral eyesight to ensure optimal visual accuracy and improve your sports performance.

### Biobased Nylon frame

The frame is made of 45% organic sourced polyamide with castor oil. The nylon material is both strong and light weighted. The Frame puts minimal strain on the nose, ears and environment at the same time.

### Biobased Nylon lens

The Biobased Nylon lens is both lighter and provides a clearer view than Polycarbonate, which is the most common material for lenses in sports glasses. The lens is flexible, resistant and has a good "memory". If you bump or bend them, they will return to their original shape. Nylon as a material is also free from BPA which is a chemically harmful substance for the body.

### Hydrophobic/Oleophobic

Our top of the line Hydrophobic + Oleophobic treatment ensures water, oil and dirt pearl off your lenses.

### 100% UV400 Protection

Our lenses block all harmful UVA, UVB & UVC light rays with wavelengths up to 400 nanometers – regardless of sun or cloud conditions.

### Interchangeable lens

The weather conditions can suddenly change, then it might be handy to have a spare lens ready. On this frame, you can easily change from one lens to a lens that is best suited for the moment. Spare lenses are available for purchase.

### Click hinge

High quality click hinge for a long-lasting temple. Free from squeaking sound, loose screws and unexpected folding.





**TRIS003-BL-003**  
 Frame: Matt black  
 Lens: Nylon Smoke. Cat 3



**TRIS003-BL-063**  
 Frame: Matt black  
 Lens: Nylon smoke/blue multi. Cat 3



**TRIS003-BR-103G**  
 Frame: Transparent brown  
 Lens: Nylon gradient brown. Cat 2



**TRIS00314**  
 Frame: Matt pink  
 Lens: Nylon brown/pink multi. Cat 3



**TRIS003-WH-203**  
 Frame: Matt white  
 Lens: Nylon purple/silver mirror. Cat 3



**TRIS003-110**  
 Frame: Shiny transparent black  
 Lens: Polarized brown/silver mirror. Cat 3



**TRIS003-111**  
 Frame: Shiny crystal  
 Lens: Polarized brown/silver mirror. Cat 3



**TRIS003-101**  
 Frame: Shiny transparent black  
 Lens: Nylon orange/blue multi. Cat 1



**TRIS003-102**  
 Frame: Shiny crystal  
 Lens: Nylon Orange/blue multi. Cat 1



**TRIS003-103**  
 Frame: Shiny transparent black  
 Lens: UltraVue nylon violet/blue multi. Cat 2



**TRIS003-104**  
 Frame: Shiny crystal  
 Lens: Nylon violet/blue multi. Cat 2



**TRIS003-108**  
 Frame: Shiny transparent black  
 Lens: Photochromic smoke/blue multi. Cat 0-3



**TRIS003-109**  
 Frame: Shiny crystal  
 Lens: Photochromic smoke/blue multi. Cat 0-3

## Spare lenses



Art.No	Spare lens
TRISL003-8	Clear - CAT 0
TRISL003-7	Pink - CAT 1
TRISL003001	Polarized brown w silver mirror - CAT 3
TRISL003002	UltraVue Orange with blue multi - CAT 1
TRISL003003	UltraVue violet with blue multi - CAT 2
TRISL003004	Smoke with blue multi - CAT 3
TRISL003005	Brown - CAT 4

48°00'24"N 17°09'38"E

# 004 Rajka

Life & Globe

BIO-BASED

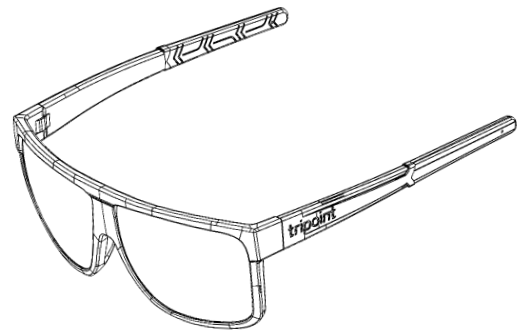

## Description

004 Rajka is your go to glasses when you're on the run and don't know how the day will end up. 004 Rajka is made to fit almost any situation.

The lens in Polycarbonate has high impact resistance and a good optical quality for clear and crisp vision. Its 100% UV protective lens will block all harmful light rays, no matter weather condition.

Keep your 004 Rajka in top condition: the storage pouch is specially designed to keep your shades safe. And the cleaning wipe keeps the dirt away, for permanent visual comfort.

### Standards

This model meets the standards EN ISO 12312-1, AS/NZS 1067 & ANSI Z80.3 for sunglasses.

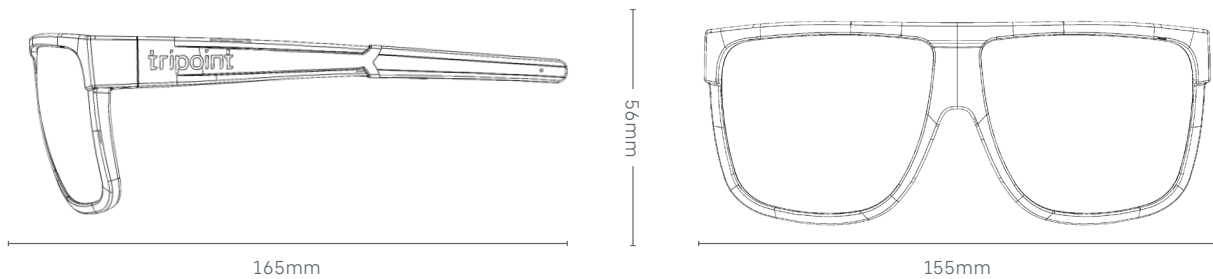

## Technical Features

### Tri-Bend Temple Tips

The rubberized temple tips are adaptable and easy to adjust to your head for a stable and comfortable use for extended periods.

### Tri-Field Full Frame

The full-frame provides a wide field of vision and enhanced peripheral vision to ensure optimal reflexes and improve your sports performance.

### Biobased Nylon frame

The frame is made of 45% organic sourced polyamide with castor oil. The nylon material are both strong and light weighted. The Frame puts minimal strain on the nose, ears and environment at the same time.

### Polycarbonate lens

The lens in Polycarbonate has high impact resistance and a good optical quality for clear and crisp vision.

### Hydrophobic/Oleophobic

Our top of the line Hydrophobic + Oleophobic treatment ensures water, oil and dirt pearl off your lenses.

### 100% UV400 Protection

Our lenses block all harmful UVA, UVB & UVC light rays with wavelengths up to 400 nanometers – regardless of sun or cloud conditions.

### Click hinge

High quality click hinge for a long-lasting temple. Free from squeaking sound, loose screws and unexpected folding.

Overview

# 004 Rajka

---



**TRIS004-BL-003**  
Frame: Matt black  
Lens: Smoke. Cat 3



**TRIS004-BR-103G**  
Frame: Transparent brown  
Lens: Gradient brown. Cat 3

1°0'S 33°55'E

# 005 Lake Victoria

Tech & Soul

BIO-  
BASED

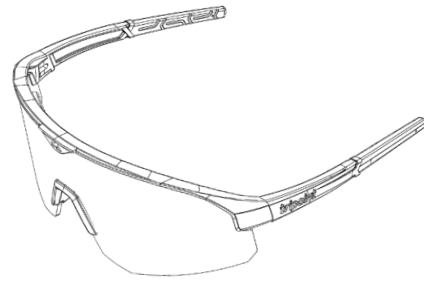

## Description

Elevate your performance and style with the 005 Lake Victoria sports glasses.

Experience the pinnacle of sports eyewear innovation with the 005 Lake Victoria model. Crafted to excel in speed sports like mountain biking, road biking, and skiing, it seamlessly merges function and fashion. environment.

Its refined design effortlessly marries form and function. The wrap-around lens provides unparalleled protection against wind and obstacles, offering a blend of elegance and performance.

The wide polycarbonate lens provide peripheral vision, clarity and high impact resistance. Equipped with a 100% UV protective lens, Lake Victoria

safeguards against tired eyes and the effects of harmful rays.

005 Lake Victoria is designed to withstand the test of time, the frame is made from 45% organic polyamide sourced from castor oil. This ensures lightweight flexibility, while its shock resistance guarantees longevity.

Keep your 005 Lake Victoria sports glasses in mint condition with the tailored storage pouch. The included cleaning wipe ensures lasting visual comfort by keeping dirt at bay.

### Standards

This model meets the standards EN ISO 12312-1, AS/NZS 1067 & ANSI Z80.3 for sunglasses.

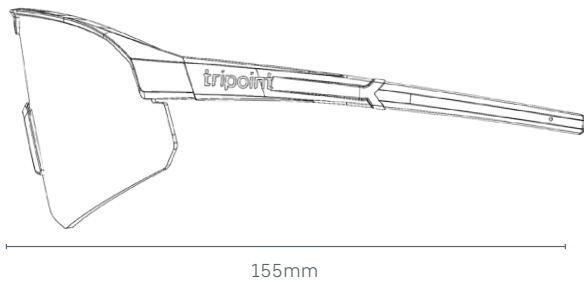

65mm

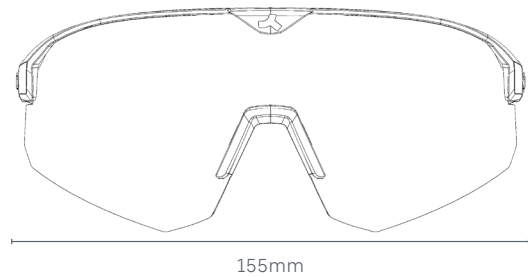

155mm

## Technical Features

### Tri-click nose System

The unique system makes the nose part easy to adjust and maintains the shape that the user himself specified. The nose part is rubber-coated and provides the user with comfort during longer and tougher forms of activity.

### Tri-Bend Temple Tips

The rubberized temple tips are adaptable and easy to adjust to your head for a stable and comfortable use for extended periods.

### Tri-field wrap-around

The wrap-around frame provides a wide field of vision and enhanced peripheral eyesight to ensure optimal visual accuracy and improve your sports performance.

### Biobased Nylon frame

The frame is made of 45% organic sourced polyamide with castor oil. The nylon material are both strong and light weighted. The Frame puts minimal strain on the nose, ears and environment at the same time.

### Polycarbonate lens

The lens in Polycarbonate has high impact resistance and a good optical quality for clear and crisp vision.

### Interchangeable lens

The weather conditions can suddenly change, then it might be handy to have a spare lens ready. On this frame, you can easily change from one lens to a lens that is best suited for the moment. Spare lenses are available for purchase.

### Hydrophobic/Oleophobic

Our top of the line Hydrophobic + Oleophobic treatment ensures water, oil and dirt peel off your lenses.

### 100% UV400 Protection

Our lenses block all harmful UVA, UVB & UVC light rays with wavelengths up to 400 nanometers – regardless of sun or cloud conditions.

### Click hinge

High quality click hinge for a long-lasting temple. Free from squeaking sound, loose screws and unexpected folding.

# Overview

## 005 Lake Victoria



**TRIS005-BL-063**  
 Frame: Matt black  
 Lens: Smoke/blue multi. Cat 3



**TRIS005-WH-063**  
 Frame: Matt white  
 Lens: Smoke/blue multi. Cat 3



**TRIS005-PN-173**  
 Frame: Matt light pink  
 Lens: Brown/pink multi. Cat 3

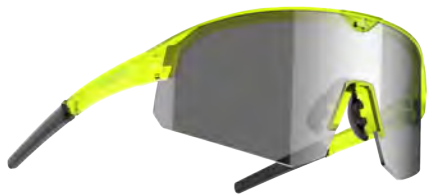

**TRIS005-YL-123**  
 Frame: Transparent neon yellow  
 Lens: Smoke. Cat 3



**TRIS005-RD-173**  
 Frame: Matt burgundy  
 Lens: Brown/pink multi. Cat 3



**TRIS005-BE-173**  
 Frame: Transparent neon turquoise  
 Lens: Brown/pink multi. Cat 3



**TRIS00514**  
 Frame: Shiny transparent black  
 Lens: UltraVue Orange/blue multi. Cat 1



**TRIS00513**  
 Frame: Shiny transparent black  
 Lens: UltraVue violet/blue multi. Cat 2



**TRIS00515**  
 Frame: Shiny transparent black  
 Lens: Photochromic smoke/blue multi. Cat 0-3

## Spare parts



Art.No	Spare lens
TRISL005-8	Clear - CAT 0
TRISL005-7	Pink - CAT 1
TRISL005-1	Smoke/blue multi - CAT 3
TRISL005-2	Brown/pink multi - CAT 3
TRISL005-3	Brown - CAT 4
TRISL005-4	UltraVue orange/blue multi - CAT 1
TRISL005-5	UltraVue violet/blue multi - CAT 2

Art.No	Optical adapter
TRIS001-OA-BL	Black
TRIS001-OA-WH	White
TRIS001-OA-BR	Transparent brown
TRIS001-OA-BE	Petrol
TRIS001-OA-PI	Powder pink
TRIS001-OA-RD	Burgundy
TRIS001-OA-YL	Transparent yellow
TRIS001-OA-BET	Transparent turquoise

# 006 1°0'S 33°55'E Lake Victoria Small

Tech & Soul

BIO-  
BASED

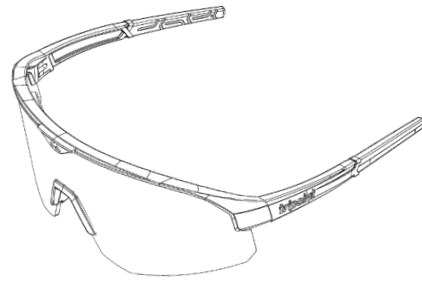

## Description

Elevate your performance and style with the 006 Lake Victoria small sports glasses.

Experience the pinnacle of sports eyewear innovation with the 006 Lake Victoria small model. Crafted to excel in speed sports like mountain biking, road biking, and skiing, it seamlessly merges function and fashion. environment.

Its refined design effortlessly marries form and function. The wrap-around lens provides unparalleled protection against wind and obstacles, offering a blend of elegance and performance.

The wide polycarbonate lens provide peripheral vision, clarity and high impact resistance. Equipped with a 100% UV protective lens, Lake Victoria

safeguards against tired eyes and the effects of harmful rays.

006 Lake Victoria is designed to withstand the test of time, the frame is made from 45% organic polyamide sourced from castor oil. This ensures lightweight flexibility, while its shock resistance guarantees longevity.

Keep your 006 Lake Victoria small sports glasses in mint condition with the tailored storage pouch. The included cleaning wipe ensures lasting visual comfort by keeping dirt at bay.

### Standards

This model meets the standards EN ISO 12312-1, AS/NZS 1067 & ANSI Z80.3 for sunglasses.

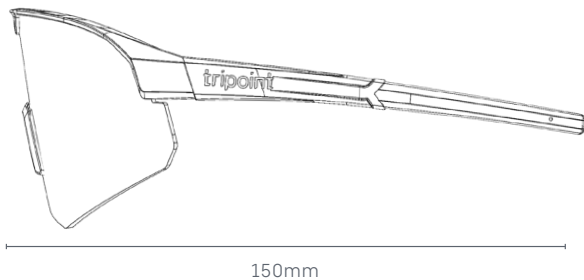

60mm

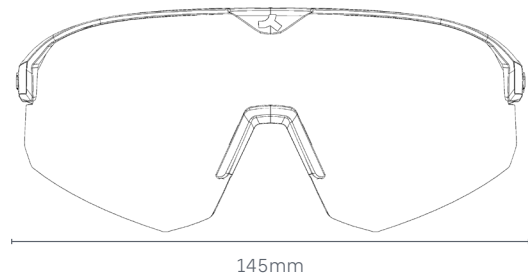

145mm

## Technical Features

### Tri-click nose System

The unique system makes the nose part easy to adjust and maintains the shape that the user himself specified. The nose part is rubber-coated and provides the user with comfort during longer and tougher forms of activity.

### Tri-Bend Temple Tips

The rubberized temple tips are adaptable and easy to adjust to your head for a stable and comfortable use for extended periods.

### Tri-field wrap-around

The wrap-around frame provides a wide field of vision and enhanced peripheral eyesight to ensure optimal visual accuracy and improve your sports performance.

### Biobased Nylon frame

The frame is made of 45% organic sourced polyamide with castor oil. The nylon material are both strong and light weighted. The Frame puts minimal strain on the nose, ears and environment at the same time.

### Polycarbonate lens

The lens in Polycarbonate has high impact resistance and a good optical quality for clear and crisp vision.

### Interchangeable lens

The weather conditions can suddenly change, then it might be handy to have a spare lens ready. On this frame, you can easily change from one lens to a lens that is best suited for the moment. Spare lenses are available for purchase.

### Hydrophobic/Oleophobic

Our top of the line Hydrophobic + Oleophobic treatment ensures water, oil and dirt peel off your lenses.

### 100% UV400 Protection

Our lenses block all harmful UVA, UVB & UVC light rays with wavelengths up to 400 nanometers – regardless of sun or cloud conditions.

### Click hinge

High quality click hinge for a long-lasting temple. Free from squeaking sound, loose screws and unexpected folding.

# Overview

## 006 Lake Victoria small



**TRIS006-BL-063**  
Frame: Matt black  
Lens: Smoke/blue multi. Cat 3



**TRIS006-WH-063**  
Frame: Matt white  
Lens: Smoke/blue multi. Cat 3



**TRIS006-PN-173**  
Frame: Matt light pink  
Lens: Brown/pink multi. Cat 3

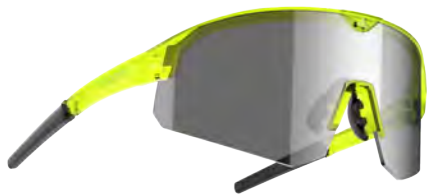

**TRIS006-YL-003**  
Frame: Transparent neon yellow  
Lens: Smoke. Cat 3



**TRIS006-RD-173**  
Frame: Matt burgundy  
Lens: Brown/pink multi. Cat 3



**TRIS006-BE-173**  
Frame: Transparent neon turquoise  
Lens: Brown/pink multi. Cat 3



**TRIS00614**  
Frame: Shiny transparent black  
Lens: UltraVue Orange/blue multi. Cat 1



**TRIS00615**  
Frame: Shiny transparent black  
Lens: UltraVue violet/blue multi. Cat 2



**TRIS00616**  
Frame: Shiny transparent black  
Lens: Photochromic smoke/blue multi. Cat 0-3

## Spare parts



Art.No	Spare lens
TRISL006-8	Clear - CAT 0
TRISL006-7	Pink - CAT 1
TRISL006-1	Smoke/blue multi - CAT 3
TRISL006-2	Brown/pink multi - CAT 3
TRISL006-3	Brown - CAT 4
TRISL006-4	UltraVue orange/blue multi - CAT 1
TRISL005-5	UltraVue violet/blue multi - CAT 2

Art.No	Optical adapter
TRIS001-OA-BL	Black
TRIS001-OA-WH	White
TRIS001-OA-BR	Transparent brown
TRIS001-OA-BE	Petrol
TRIS001-OA-PI	Powder pink
TRIS001-OA-RD	Burgundy
TRIS001-OA-YL	Transparent yellow
TRIS001-OA-BET	Transparent turquoise

# 011 1°0'S 33°55'E Lake Victoria X-Small

Tech & Soul

BIO-  
BASED

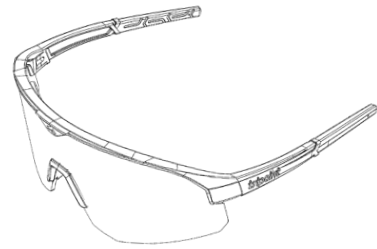

## Description

Elevate your performance and style with the 011 Lake Victoria X-small sports glasses for extra small faces and kids.

Experience the pinnacle of sports eyewear innovation with the 011 Lake Victoria X-small model. Crafted to excel in speed sports like mountain biking, road biking, and skiing, it seamlessly merges function and fashion. environment.

Its refined design effortlessly marries form and function. The wrap-around lens provides unparalleled protection against wind and obstacles, offering a blend of elegance and performance.

The wide polycarbonate lens provide peripheral vision, clarity and high impact resistance. Equipped with a 100% UV protective lens, Lake Victoria

safeguards against tired eyes and the effects of harmful rays.

011 Lake Victoria X-small is designed to withstand the test of time, the frame is made from 45% organic polyamide sourced from castor oil. This ensures lightweight flexibility, while its shock resistance guarantees longevity.

Keep your 011 Lake Victoria small sports glasses in mint condition with the tailored storage pouch. The included cleaning wipe ensures lasting visual comfort by keeping dirt at bay.

### Standards

This model meets the standards EN ISO 12312-1, AS/NZS 1067 & ANSI Z80.3 for sunglasses.

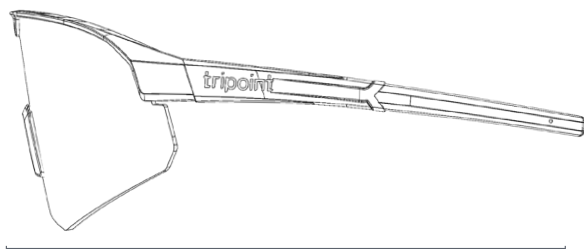

140mm

55mm

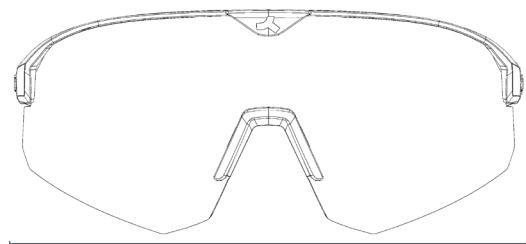

135mm

## Technical Features

### Tri-click nose System

The unique system makes the nose part easy to adjust and maintains the shape that the user himself specified. The nose part is rubber-coated and provides the user with comfort during longer and tougher forms of activity.

### Tri-Bend Temple Tips

The rubberized temple tips are adaptable and easy to adjust to your head for a stable and comfortable use for extended periods.

### Tri-field wrap-around

The wrap-around frame provides a wide field of vision and enhanced peripheral eyesight to ensure optimal visual accuracy and improve your sports performance.

### Biobased Nylon frame

The frame is made of 45% organic sourced polyamide with castor oil. The nylon material are both strong and light weighted. The Frame puts minimal strain on the nose, ears and environment at the same time.

### Polycarbonate lens

The lens in Polycarbonate has high impact resistance and a good optical quality for clear and crisp vision.

### Interchangeable lens

The weather conditions can suddenly change, then it might be handy to have a spare lens ready. On this frame, you can easily change from one lens to a lens that is best suited for the moment. Spare lenses are available for purchase.

### Hydrophobic/Oleophobic

Our top of the line Hydrophobic + Oleophobic treatment ensures water, oil and dirt peel off your lenses.

### 100% UV400 Protection

Our lenses block all harmful UVA, UVB & UVC light rays with wavelengths up to 400 nanometers – regardless of sun or cloud conditions.

### Click hinge

High quality click hinge for a long-lasting temple. Free from squeaking sound, loose screws and unexpected folding.



# Overview

## 011 Lake Victoria X-small

---



**TS0020S001**  
Frame: Transparent neon turquoise  
Lens: Brown/pink multi. Cat 3



**TS0020S002**  
Frame: Matt black  
Lens: Smoke/blue multi. Cat 3



**TS0020S004**  
Frame: Matt light pink  
Lens: Brown/pink multi. Cat 3



**TS0020S005**  
Frame: Matt white  
Lens: Smoke/blue multi. Cat 3

### Spare parts



**Art.No**  
TS0020E101  
TS0020E102

**Spare lens**  
Clear - CAT 0  
Smoke/blue multi - CAT 3

# 007 17°47'16"S 25°15'24"E Chobe

Tech & Soul

BIO-  
BASED

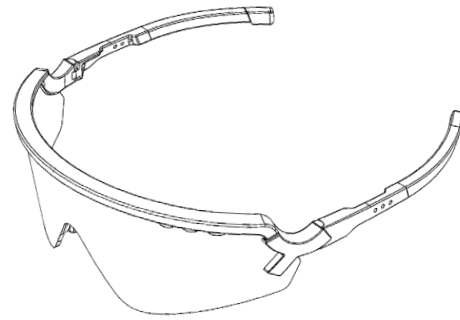

## Description

Elevate your performance and step up your style game with the remarkable 007 Chobe sports glasses. These versatile frames are carefully engineered to cater to your every multisport need. The high basecurve design ensures a snug fit against your face, making them the perfect choice for both gusty winds and radiant sunshine.

Crafted to excel in high-speed sports such as mountain biking, road biking, surfing and skiing, it effortlessly blends fashion with function.

Its sleek design seamlessly marries aesthetics and practicality. The wrap-around lens offers unmatched protection against wind and obstacles, marrying elegance with top-tier performance. It's like having a second skin glued to your face.

The wide polycarbonate lens delivers exceptional peripheral vision, crystal-clear clarity, and remarkable high-im-

pact resistance. Equipped with a 100% UV protective lens, the 007 Chobe safeguards your eyes against fatigue and the harmful effects of UV rays.

Designed for longevity, the 007 Chobe frame is constructed from 45% organic polyamide sourced from castor oil. This ensures lightweight flexibility, while its shock resistance guarantees lasting durability.

To maintain the pristine condition of your 008 Lake Prespa sports glasses, we offer a customized storage pouch that doubles as a cleaning cloth. Additionally, you'll receive a hard case with a magnetic lock, and it can be flat-packed for convenience.

### Standards

This model meets the standards EN ISO 12312-1, AS/NZS 1067 & ANSI Z80.3 for sunglasses.

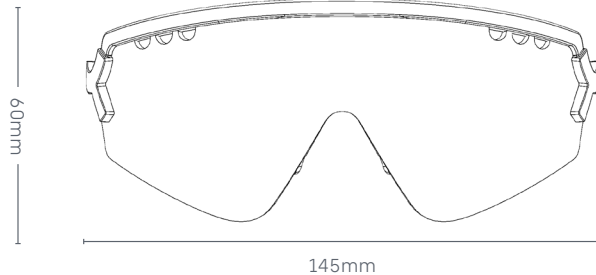
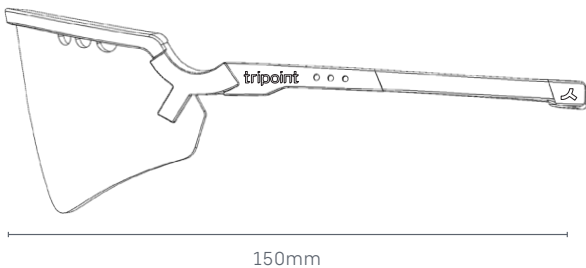

## Technical Features

### Tri-flex Nose System

This unique system allows for easy adjustment of the nose piece at any angle specified by the user. The nose piece is rubber-coated, providing comfort during extended and more strenuous activities.

### Tri-Bend Temple Tips

The rubberized temple tips are adaptable and easy to adjust to your head for a stable and comfortable use for extended periods.

### Tri-field wrap-around

The wrap-around frame provides a wide field of vision and enhanced peripheral eyesight to ensure optimal visual accuracy and improve your sports performance.

### Biobased Nylon frame

The frame is made of 45% organic sourced polyamide with castor oil. The nylon material are both strong and light weighted. The Frame puts minimal strain on the nose, ears and environment at the same time.

### Polycarbonate lens

The lens in Polycarbonate has high impact resistance and a good optical quality for clear and crisp vision.

### Interchangeable lens

The weather conditions can suddenly change, then it might be handy to have a spare lens ready. On this frame, you can easily change from one lens to a lens that is best suited for the moment. Spare lenses are available for purchase.

### Hydrophobic/Oleophobic

Our top of the line Hydrophobic + Oleophobic treatment ensures water, oil and dirt pearl off your lenses.

### 100% UV400 Protection

Our lenses block all harmful UVA, UVB & UVC light rays with wavelengths up to 400 nanometers – regardless of sun or cloud conditions.

### Click hinge

High quality click hinge for a long-lasting temple. Free from squeaking sound, loose screws and unexpected folding.

### Floating Neck Cord

Included with your sports glasses is an attachable neck cord for added convenience. This neck cord boasts a unique floating feature, ensuring that should you accidentally drop your glasses in the water, they'll stay afloat and easily retrievable.

Moreover, it's a handy accessory if you prefer to keep your glasses hanging around your neck when they're not in use. With this floating neck cord, you get both practical functionality and peace of mind, making it a valuable addition to your sports eyewear.

# Overview

## 007 Chobe



**TS0007S011**  
 Frame: Matt light purple  
 Lens: Purple/purple multi. Cat 2

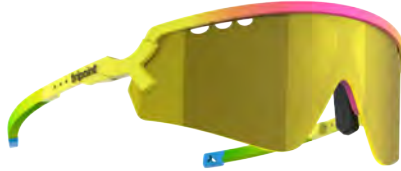

**TS0007S012**  
 Frame: Multi color  
 Lens: Brown/yellow multi. Cat 3



**TS0007S013**  
 Frame: Matt black  
 Lens: Brown/bronze multi. Cat 3



**TS0007S015**  
 Frame: Matt White  
 Lens: Brown/pink multi. Cat 3



**TS0007S001**  
 Frame: Shiny transparent black  
 Lens: Polarized brown/silver mirror. Cat 3



**TS0007S002**  
 Frame: Shiny crystal  
 Lens: Polarized brown/silver mirror. Cat 3



**TS0007S005**  
 Frame: Shiny transparent black  
 Lens: UltraVue Orange/blue multi. Cat 1



**TS0007S006**  
 Frame: Shiny crystal  
 Lens: UltraVue Orange/blue multi. Cat 1



**TS0007S007**  
 Frame: Shiny transparent black  
 Lens: UltraVue violet/blue multi. Cat 2



**TS0007S008**  
 Frame: Shiny crystal  
 Lens: UltraVue violet/blue multi. Cat 2



**TS0007S003**  
 Frame: Shiny transparent black  
 Lens: Photochromic smoke/blue multi.  
 Cat 0-3

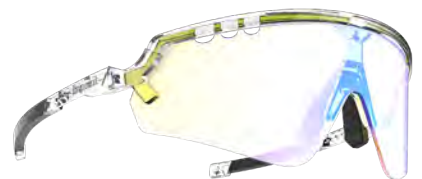

**TS0007S004**  
 Frame: Shiny crystal  
 Lens: Photochromic smoke/blue multi.  
 Cat 0-3

## Spare lenses



Art.No	Spare lens
TS0007E101	Smoke/blue multi - CAT 3
TS0007E102	Brown/Pink multi - CAT 3
TS0007E103	Brown - CAT 4
TS0007E104	UltraVue Orange/blue multi - CAT 1
TS0007E105	UltraVue violet/blue multi - CAT 2
TS0007E106	Clear - CAT 0

# 008 40°51'06"N 20°59'00"E Lake Prespa

Life & Globe

BIO-BASED

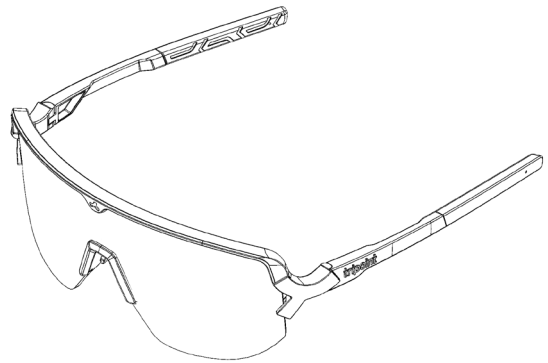

## Description

Embrace the half-frame allure with a bio-based nylon frame that effortlessly balances sporty functionality with casual elegance. The hybrid design caters to both active pursuits and laid-back occasions, offering versatility for any setting.

Ideal for activities like: Running, cycling, hiking and climbing. After completing your sport, seamlessly transition from athletic activities to leisure, highlighting its versatile appeal.

Its characteristic yet sleek design effortlessly combines aesthetics and practicality. The straight lens with a low base curve provides unparalleled protection against wind and obstacles, blending elegance with top-tier performance.

The polycarbonate lens not only provides clarity but also shields against wind, dirt, and bugs, ensuring a comfortable experience.

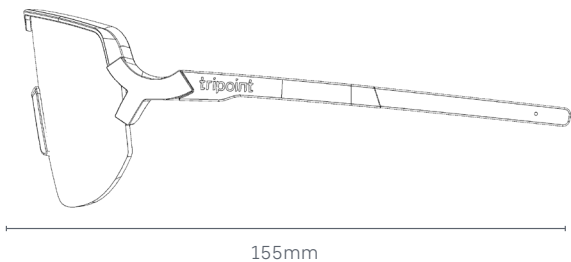

155mm

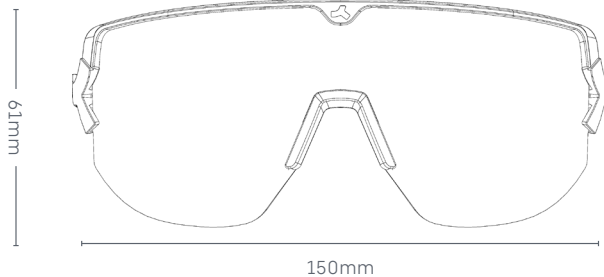

61mm

150mm

Equipped with a 100% UV protective lens, the 008 Lake Prespa protect your eyes against fatigue and the harmful effects of UV rays.

Designed for longevity, the 008 Lake Prespa frame is constructed from 45% organic polyamide sourced from castor oil. This ensures lightweight flexibility, while its shock resistance guarantees lasting durability.

To maintain the pristine condition of your 008 Lake Prespa sports glasses, we offer a customized storage pouch that doubles as a cleaning cloth. Additionally, you'll receive a hard case with a magnetic lock, and it can be flat-packed for convenience.

### Standards

This model meets the standards EN ISO 12312-1, AS/NZS 1067 & ANSI Z80.3 for sunglasses.

## Technical Features

### Tri-click nose system

The unique system makes the nose part easy to adjust and maintains the shape that the user himself specified. The nose part is rubber-coated and provides the user with comfort during longer and tougher forms of activity.

### Tri-Bend Temple Tips

The rubberized temple tips are adaptable and easy to adjust to your head for a stable and comfortable use for extended periods.

### Tri-field half frame

The full-frame provides a wide field of vision and enhanced peripheral eyesight to ensure optimal visual accuracy and improve your sports performance.

### Biobased Nylon frame

The frame is made of 45% organic sourced polyamide with castor oil. The nylon material are both strong and light weighted. The Frame puts minimal strain on the nose, ears and environment at the same time.

### Polycarbonate lens

The lens in Polycarbonate has high impact resistance and a good optical quality for clear and crisp vision.

### Interchangeable lens

The weather conditions can suddenly change, then it might be handy to have a spare lens ready. On this frame, you can easily change from one lens to a lens that is best suited for the moment. Spare lenses are available for purchase.

### Hydrophobic/Oleophobic

Our top of the line Hydrophobic + Oleophobic treatment ensures water, oil and dirt pearl off your lenses.

### 100% UV400 Protection

Our lenses block all harmful UVA, UVB & UVC light rays with wavelengths up to 400 nanometers – regardless of sun or cloud conditions.

### Click hinge

High quality click hinge for a long-lasting temple. Free from squeaking sound, loose screws and unexpected folding.

# Overview

## 008 Lake Prespa

---



**TS0008S014**  
Frame: Matt black  
Lens: Brown/red multi. Cat 3



**TS0008S015**  
Frame: Matt metallic white  
Lens: Brown/pink multi. Cat 3



**TS0008S013**  
Frame: Shiny neon orange  
Lens: Smoke. Cat 3



**TS0008S016**  
Frame: Matt black  
Lens: Smoke/blue multi. Cat 3



**TS0008S017**  
Frame: Matt pink  
Lens: Brown/pink multi. Cat 3



**TS0008S018**  
Frame: Matt burgundy  
Lens: Brown/pink multi. Cat 3

### Spare lenses



Art.No	Spare lens
TS0008E101	Clear - CAT 0
TS0008E102	Pink - CAT 1
TS0008E103	UltraVue Orange/blue multi - CAT 1
TS0008E104	UltraVue violet/blue multi - CAT 2
TS0008E105	Brown - CAT 4
TS0008E106	Brown/pink multi - CAT 3
TS0008E107	Smoke/blue multi - CAT 3

# 009 40°51'06"N 20°59'00"E Lake Prespa

Life & Globe

BIO-BASED

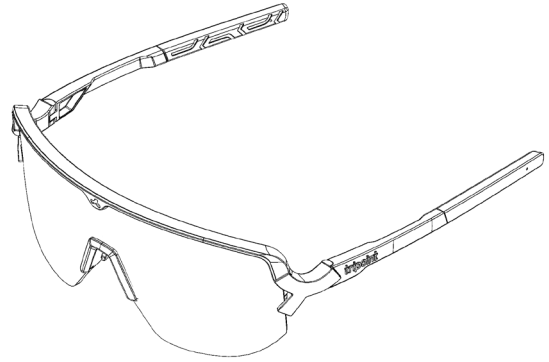

## Description

Embrace the half-frame allure with a bio-based nylon frame that effortlessly balances sporty functionality with casual elegance. The hybrid design caters to both active pursuits and laid-back occasions, offering versatility for any setting.

Ideal for activities like: Running, cycling, hiking and climbing. After completing your sport, seamlessly transition from athletic activities to leisure, highlighting its versatile appeal.

Its characteristic yet sleek design effortlessly combines aesthetics and practicality. The straight lens with a low base curve provides unparalleled protection against wind and obstacles, blending elegance with top-tier performance.

The polycarbonate lens not only provides clarity but also shields against wind, dirt, and bugs, ensuring a comfortable experience.

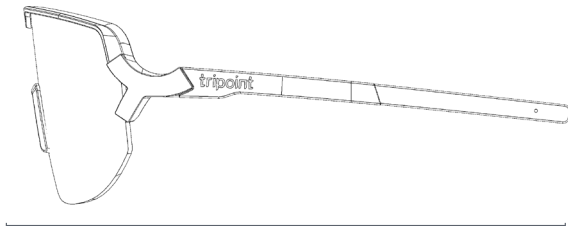

150mm

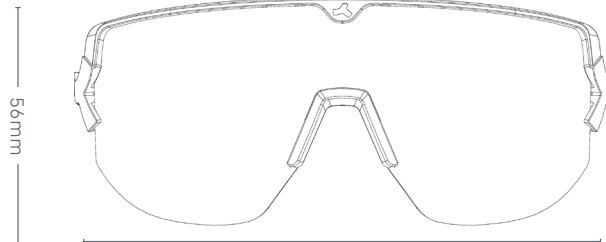

56mm

141mm

Equipped with a 100% UV protective lens, the 009 Lake Prespa Small protect your eyes against fatigue and the harmful effects of UV rays.

Designed for longevity, the 009 Lake Prespa Small frame is constructed from 45% organic polyamide sourced from castor oil. This ensures lightweight flexibility, while its shock resistance guarantees lasting durability.

To maintain the pristine condition of your 009 Lake Prespa Small sports glasses, we offer a customized storage pouch that doubles as a cleaning cloth. Additionally, you'll receive a hard case with a magnetic lock, and it can be flat-packed for convenience.

### Standards

This model meets the standards EN ISO 12312-1, AS/NZS 1067 & ANSI Z80.3 for sunglasses.

## Technical Features

### Tri-click nose system

The unique system makes the nose part easy to adjust and maintains the shape that the user himself specified. The nose part is rubber-coated and provides the user with comfort during longer and tougher forms of activity.

### Tri-Bend Temple Tips

The rubberized temple tips are adaptable and easy to adjust to your head for a stable and comfortable use for extended periods.

### Tri-field half frame

The full-frame provides a wide field of vision and enhanced peripheral eyesight to ensure optimal visual accuracy and improve your sports performance.

### Biobased Nylon frame

The frame is made of 45% organic sourced polyamide with castor oil. The nylon material are both strong and light weighted. The Frame puts minimal strain on the nose, ears and environment at the same time.

### Polycarbonate lens

The lens in Polycarbonate has high impact resistance and a good optical quality for clear and crisp vision.

### Interchangeable lens

The weather conditions can suddenly change, then it might be handy to have a spare lens ready. On this frame, you can easily change from one lens to a lens that is best suited for the moment. Spare lenses are available for purchase.

### Hydrophobic/Oleophobic

Our top of the line Hydrophobic + Oleophobic treatment ensures water, oil and dirt pearl off your lenses.

### 100% UV400 Protection

Our lenses block all harmful UVA, UVB & UVC light rays with wavelengths up to 400 nanometers – regardless of sun or cloud conditions.

### Click hinge

High quality click hinge for a long-lasting temple. Free from squeaking sound, loose screws and unexpected folding.

# Overview

## 009 Lake Prespa Small



**TS0009S006**  
Frame: Matt black  
Lens: Brown/red multi. Cat 3



**TS0009S007**  
Frame: Matt metallic white  
Lens: Brown/pink multi. Cat 3



**TS0009S005**  
Frame: Shiny neon orange  
Lens: Smoke. Cat 3



**TS0009S008**  
Frame: Matt black  
Lens: Smoke/blue multi. Cat 3



**TS0009S009**  
Frame: Matt pink  
Lens: Brown/pink multi. Cat 3



**TS0009S010**  
Frame: Matt burgundy  
Lens: Brown/pink multi. Cat 3

### Spare lenses



Art.No	Spare lens
TS0009E101	Clear - CAT 0
TS0009E102	Pink - CAT 1
TS0009E103	UltraVue orange/blue multi - CAT 1
TS0009E104	UltraVue violet/blue multi - CAT 2
TS0009E105	Brown - CAT 4
TS0009E106	Brown/pink multi - CAT 3
TS0009E107	Smoke/blue multi - CAT 3

17°30'S 69°29'W

# 010 Visviri

Life & Globe

BIO-BASED

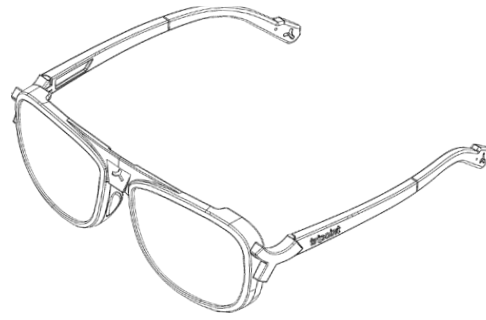

## Description

Discover the perfect fusion of style and functionality with our latest eyewear 010 Visviri. Featuring a classic design enhanced by sporty materials, these glasses boast a lightweight biobased nylon frame. Equipped with friction rubber tips and nose parts for a secure fit. Perfect for both sport and fashion, these glasses are your ideal companion for any occasion.

The lenses in Polycarbonate has high impact resistance and a good optical quality for clear and crisp vision. Its 100% UV protective lens will block all harmful light rays, no matter weather condition.

To maintain the pristine condition of your 010 Visviri, we offer a customized storage pouch that doubles as a cleaning cloth. Additionally, you'll receive a hard case with a magnetic lock, and it can be flat-packed for convenience.

### Standards

This model meets the standards EN ISO 12312-1, AS/NZS 1067 & ANSI Z80.3 for sunglasses.

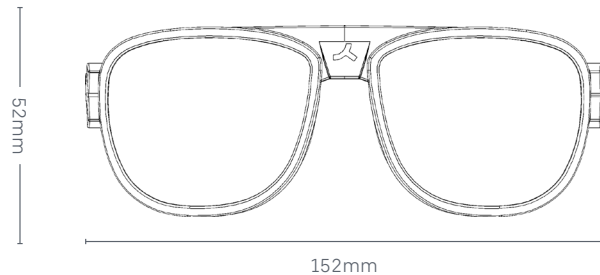
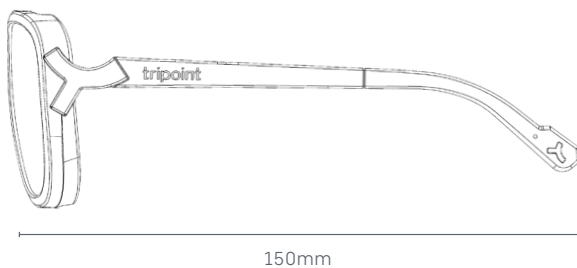

## Technical Features

### Friction rubber nose piece & temple tips

The rubberized nose piece & temple tips are gentle and soft to your skin for a stable and comfortable use for extended periods.

### Tri-Field Full Frame

The full-frame provides a wide field of vision and enhanced peripheral vision to ensure optimal reflexes and improve your sports performance.

### Biobased Nylon frame

The frame is made of 45% organic sourced polyamide with castor oil. The nylon material are both strong and light weighted. The Frame puts minimal strain on the nose, ears and environment at the same time.

### Polycarbonate lens

The lens in Polycarbonate has high impact resistance and a good optical quality for clear and crisp vision.

### Hydrophobic/Oleophobic

Our top of the line Hydrophobic + Oleophobic treatment ensures water, oil and dirt pearl off your lenses.

### 100% UV400 Protection

Our lenses block all harmful UVA, UVB & UVC light rays with wavelengths up to 400 nanometers – regardless of sun or cloud conditions.

### Click hinge

High quality click hinge for a long-lasting temple. Free from squeaking sound, loose screws and unexpected folding.



# Overview

## 010 Visviri

---



**TS0019S001**  
Frame: Matt black  
Lens: Smoke. Cat 3



**TS0019S002**  
Frame: Shiny transparent brown  
Lens: Gradient brown. Cat 2



**TS0019S003**  
Frame: Shiny olive green  
Lens: Green. Cat 3



**TS0019S004**  
Frame: Matt white  
Lens: Smoke/blue multi. Cat 3

# Merch



TM0004M001-XS-XXL  
Tripoint Hoodie

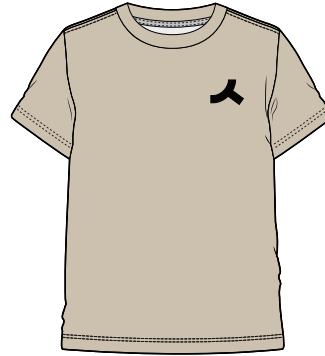

TM0003M001 -XS-XXL  
Tripoint T-Shirt regular

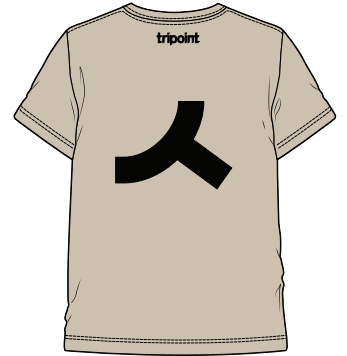

TRIM4-WH-OZ  
Cap



TM0005M001  
Tripoint beanie regular



TM0007M001  
Tripoint beanie active

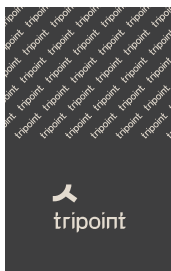

TM0008M001  
Buff

# Displays



Wooden small sign Tripoint Logo



Wooden Desk display



Wooden floor combi

Tripoint Combi Floor



Goggles



Helmets



